

DIMENSIONS AND TOLERANCES IN INCHES UNLESS OTHERWISE SPECIFIED:

BREAK CORNERS 0.005" - 0.015"

DECIMALS
 0.X +/- .03
 0.XX +/- 0.01
 0.XXX +/- 0.005

PROJECTION ANGLE

FRACTIONS +/- 1/16"
 ANGLES +/- 1 DEGREE

UNLESS OTHERWISE SPECIFIED ALL STEEL SPECIFICATIONS ARE:
 HRS PLATE --- A36
 HRS BAR --- A36 OR 1020
 ALLOY BAR --- 4140/4142 HEAT TREATED

WELDING STANDARDS:
 SEE 359370 DOCUMENT ON JHF WELDING STANDARDS AND SPECIFICATIONS. WELD SYMBOLS OR NOTES ON DRAWING SUPERCEDE 359370 DOCUMENT

J. H. FLETCHER & CO. ©

THIS DRAWING IN DESIGN AND DETAIL IS OUR PROPERTY AND MUST NOT BE USED EXCEPT IN CONNECTION WITH OUR WORK. ALL RIGHTS OF DESIGN OR INVENTION ARE RESERVED.

CJ151E FACE DRILL

LEVEL	DATE	BY	REVISION
A	10/1/10	SCF	RELEASED
DO NOT CHANGE MANUALLY			
MAT'L		WT.	0.0 lbm

BY	SHEET	DWG	REV
SCF	1 OF 2	16-06-35-66	A

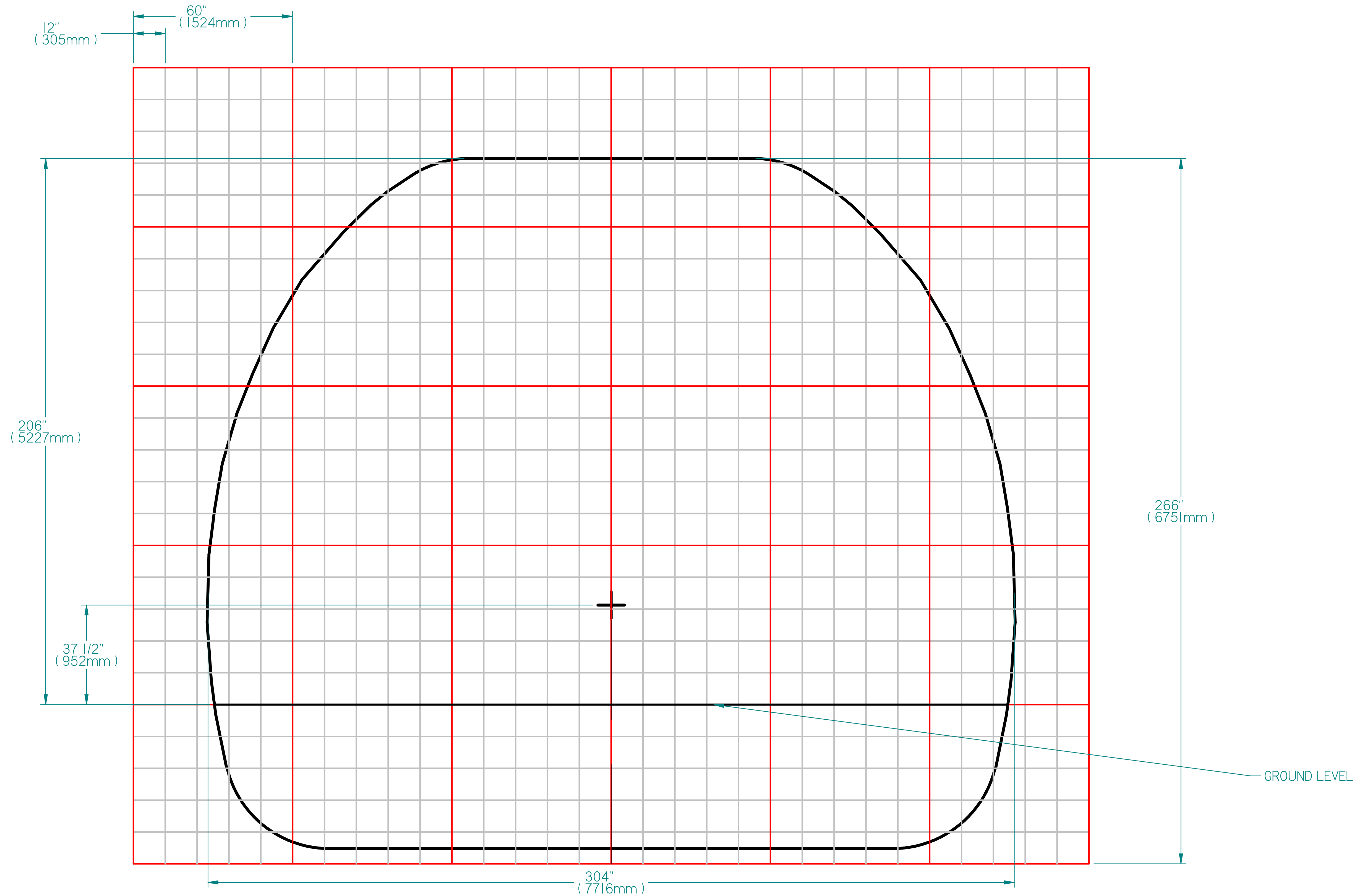

DIMENSIONS AND TOLERANCES IN INCHES
UNLESS OTHERWISE SPECIFIED:

BREAK CORNERS
0.005" - 0.015"

DECIMALS
0.X +/- .03
0.XX +/- 0.01
0.XXX +/- 0.005

FRACTIONS +/- 1/16"
ANGLES +/- 1 DEGREE

UNLESS OTHERWISE SPECIFIED ALL STEEL SPECIFICATIONS ARE:
HRS PLATE --- A36
HRS BAR --- A36 OR 1020
ALLOY BAR --- 4140/4142 HEAT TREATED

WELDING STANDARDS:
SEE 359370 DOCUMENT ON JHF WELDING STANDARDS AND SPECIFICATIONS. WELD SYMBOLS OR NOTES ON DRAWING SUPERCEDE 359370 DOCUMENT

J. H. FLETCHER & CO. ©

THIS DRAWING IN DESIGN AND DETAIL IS OUR PROPERTY AND MUST NOT BE USED EXCEPT IN CONNECTION WITH OUR WORK. ALL RIGHTS OF DESIGN OR INVENTION ARE RESERVED.

CJ151E FACE DRILL

LEVEL	DATE	BY	REVISION

DO NOT CHANGE MANUALLY

MAT'L	WT.
-------	-----

BY	SHEET	DWG	REV
SCF	2 OF 2	16-06-35-66	A