

FLETCHER

MRS: Mobile Roof Support



Mobile Roof Supports For Coal Pillar Extraction

*Safe and productive
method for increased
reserve recovery*

J. H. Fletcher & Co.
P.O. Box 2187
Huntington, WV 25722-2187
jhf@jhfletcher.com
304-525-7811

16' maximum height available

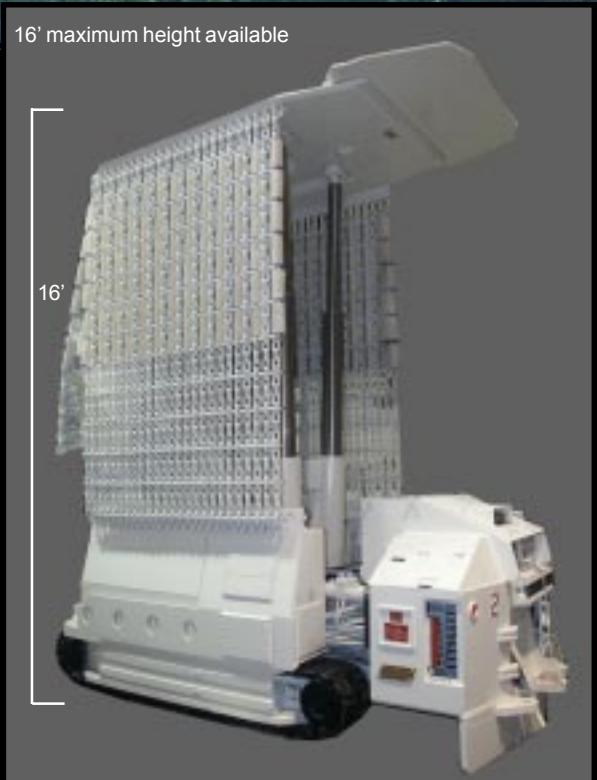

Why Mobile Roof Supports?...

As the need for productive mining alternatives increase, the number of mining operations using Mobile Roof Supports for retreat mining is growing. The mining industry is seeing that, when properly used, Mobile Roof Supports can allow the economic recovery of reserves with a higher degree of safety and improved productivity.

...Safety and Productivity

- No back injuries from lifting and setting timbers, the need for timbers is nearly eliminated
- Decreased exposure to roof and rib falls
- Less personnel required in work area
- Caving is more regular and somewhat predictable, reducing the hazards associated with unexpected caving
- Higher recovery rate of pillar
- Less time is required making the overall operation more efficient and safer

Features



Roof Support Assembly

- Rugged design made from high strength alloy steel.
- Sloped edges to minimize lateral stress and to allow support to tram clear through loose roof material
- Available with tilting lemniscate and roof support assembly for uneven seam conditions
- +/- 15 degree side to side roof support assembly movement to match roof horizon.
- +/- 25 degree front to rear operator controlled canopy tilt
- Heavy gauge chain curtain and optional belt lacing to protect internal components



Load Monitoring

- Provides a visual indication of current machine loading as well as changes in loading
- Alerts the miner operator to load changes that may require immediate action on his part



Caving Shield

- Caving shield extends toward gob providing increased machine components protection and can assist in pushing the MRS from heavily caved areas
- Forms part of a sturdy lemniscate system for a strong chassis to roof support connection



Plow

- Rugged plow design encloses cable reel, electrical and hydraulic controls for accessibility and protection
- Plow configuration allows loose floor material to be handled in the normal pillaring cycle without interrupting production
- Plow can move above frame underclearance and below ground level. Powerful enough to raise MRS from the floor



Crawler Frame

- Well balanced, maneuverable. 16” crawler pads
- Fully load bearing, constructed to transmit support load to mine floor
- Powerful crawler drive system provides superior tramming capabilities in adverse conditions and a high degree of maneuverability
- Automatic speed and torque control built into the tram system



Hydraulic System and Support Cylinders

- Variable displacement, 45 gpm piston pump
- Pilot operated hydraulic valves via MSHA certified solenoids make up a simple control system
- All cylinders constructed with high pressure, wear resistant seals and wipers
- 600 ton and 800 ton load capabilities available



Remote Control

- Radio remote and pendant control
- Transmitter is small, lightweight, and easy to handle with pressure sensitive sealed membrane touch pad controls
- Fire suppression system can be actuated by radio, automatically, or manually.
- Transmitter powered by approved 9v battery

Services and Support

- Machines are designed to match specific needs of your coal seam and mining plan
- Transport trailers are available to move MRS units from section to section
- Onsite operator and supervisor training and assistance provided for MRS operation and maintenance
- Assistance with developing your mining plan for MSHA approval
- Assistance with developing detail operational procedures using Mobile Roof Supports
- Supported by experienced sales and service personnel as well as a nationwide parts distribution network

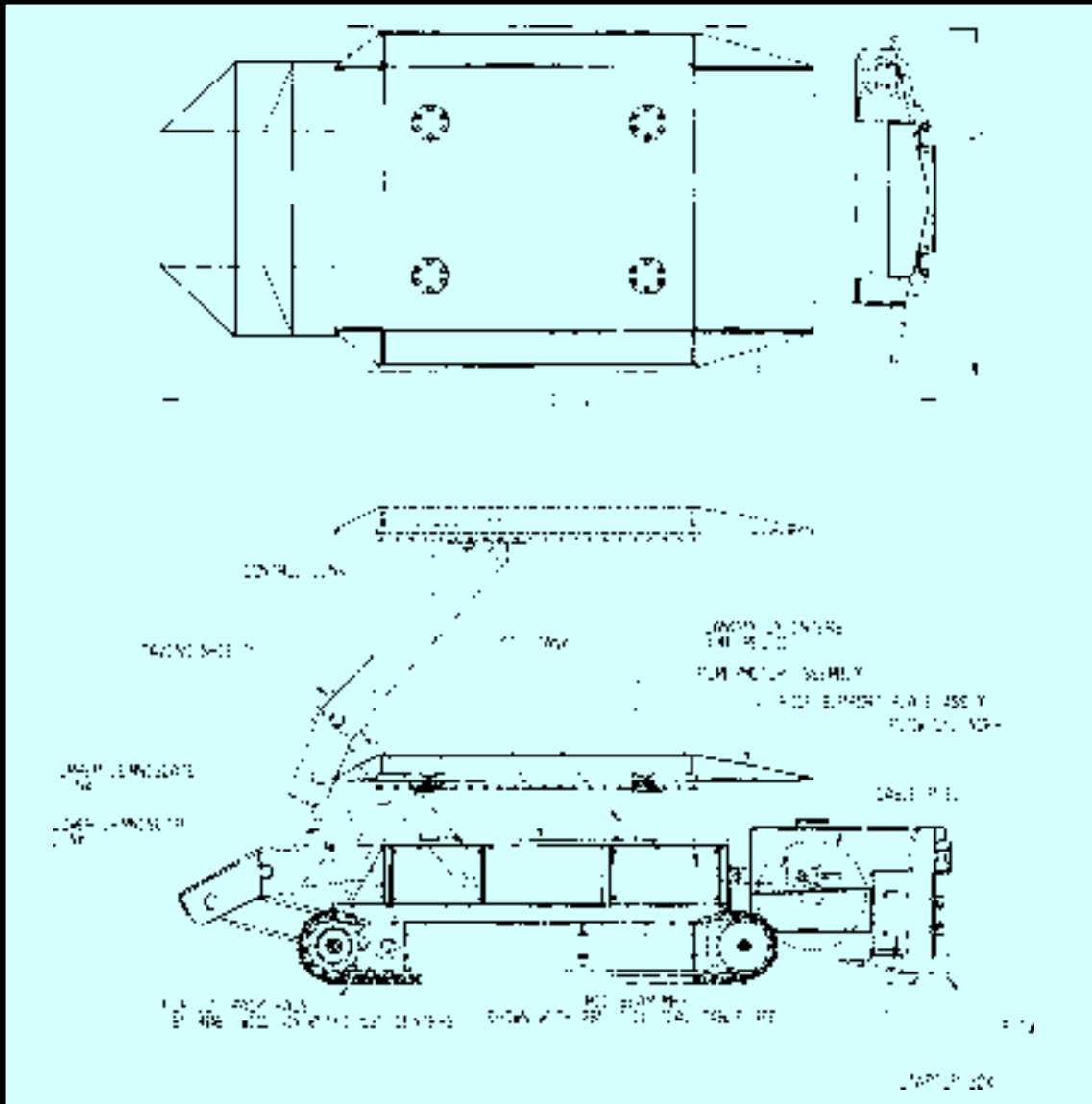

600 TON MRS		UNDER CLEARANCE
EXTENDED	COLLAPSED	
63"	32"	5"
72"	36"	6"
86"	40"	6"
100"	45"	6"
120"	50"	6"
145"	57"	8"

800 TON MRS		UNDER CLEARANCE
EXTENDED	COLLAPSED	
86"	42"	6"
110"	50"	8"
132"	59"	8"
144"	68"	8"
174"	83"	9" *
196"	91"	11" *

* Tilt frame design

J. H. Fletcher & Co. cannot anticipate every mine hazard that may develop during use of these products. A roof control plan must be approved by MSHA before use of these products begins. Proper use, maintenance and continued use of (OEM) original equipment parts will be essential for maximum operating results.

Specifically engineered for each customer's needs.



J. H. Fletcher & Co.
 P.O. Box 2187
 Huntington, WV 25722-2187
jhf@jhfletcher.com
 304-525-7811