

# FLETCHER

Model 3250RD

High Reach Scaler



Over 50ft Reach

The Fletcher Model 3250RD Scaler with its extending boom is capable of reaching over 50'. With the Fletcher high reach scaler you get reliability, quality workmanship, longer machine life and support from experienced sales and service personnel.

## Features

- 50' Reach
- 80000 GVW
- 224 HP John Deere Engine
- 2 and 4 Wheel Drive Configurations
- Nitrogen charged strut suspension
- Axle static load rating of 101000 LBS each
- Spring set wet disc brakes
- FOPS Cab structure with rock guard

- Triangular heavy duty boom weighing 480 LBS/ft
- High capacity turntable and swing drive
- Load sensing hydraulic system
- Sound insulated cab
- Joystick controls
- 360° Tool rotation
- Air Conditioned
- 14' Boom extension



*Specifically engineered for each customer's needs.*

**J. H. Fletcher & Co.**  
402 High St. P.O. Box 2187  
Huntington, WV 25722-2187  
jhf@jhletcher.com  
304-525-7811

# Model 3250RD

# High Reach Scaler

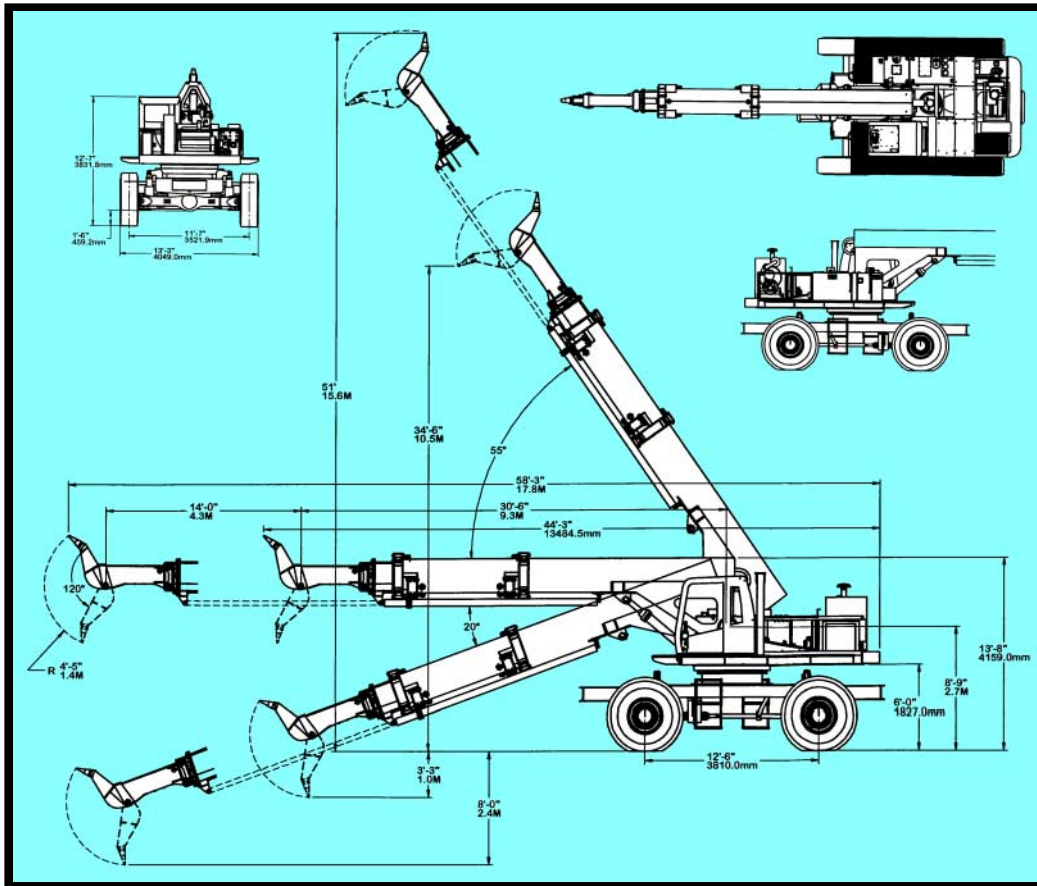

360° Tool rotation with pick or optional hydraulic breaker or cutter drum.



Certified Falling Object Protective (FOP) cab structure with rock guard. Cab features include 5 point operator safety harness, sound insulation, air conditioning, suspension seat and easy to use joystick controls.



Totally enclosed wet disk brakes on each wheel and nitrogen charged strut suspension

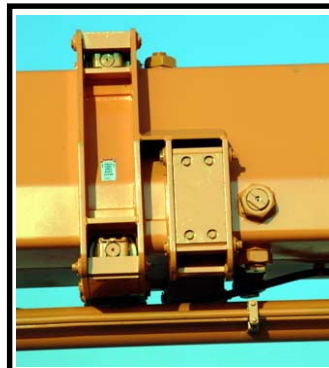

Easily accessible boom roller assembly contributes to smooth operation of the 14' boom extend feature.

J. H. Fletcher & Co. cannot anticipate every mine hazard that may develop during use of these products. A roof control plan must be approved by MSHA before use of these products begins. Proper use, maintenance and continued use of (OEM) original equipment parts will be essential for maximum operating results.