

J. H. FLETCHER & CO. Box 2187 – Huntington, WV 25722-2187 – 304/525-7811 – FAX 304/525-4025

IMPORTANT SAFETY NOTICE

INFORMATION BULLETIN NO. 90

TO:	ALL OWNERS, OPERATORS AND REBUILDERS OF J.H. FLETCHER & CO. ROOF BOLTERS
FROM:	J.H. FLETCHER & CO.
DATE:	DECEMBER 2002
SUBJECT:	FATAL ACCIDENT ALERT AND SAFETY WARNING REMINDERS REGARDING UNAUTHORIZED MACHINE ALTERATION AND SINGLE FUNCTION FAST FEED MECHANISM

On December 13, 2002 a fatal accident occurred at a coal mine in Eastern Kentucky. At this time, the accident investigation is incomplete. The Kentucky Department of Mines and Minerals and the Federal Mine Safety and Health Administration (MSHA) are conducting their investigation.

Preliminary information obtained by J.H. Fletcher & Co. through its participation in the investigation reveals that an operator became crushed between the boom arm and canopy. The roof-bolting machine was substantially and materially altered from its original J.H. Fletcher & Co. design. Before the machine could be returned to service underground, MSHA directed the owner to make multiple safety related modifications.

J.H. Fletcher & Co. is sending out this bulletin to remind all purchasers, consumers and users of its equipment of its previously published warnings about the open and obvious pinch point inherent to a roof bolting machine; the essential requirement that an operator never position any portion of his body in the pinch point; and the devastating and life/limb threatening consequences of material and unauthorized machine alteration.

In the December 13 accident, the operator was using an arm feed machine. Arm feed roof-bolting machines incorporate an arm feed boom arrangement. This arrangement allows the boom arm to support the drillhead in the drilling and bolt insertion cycle. In this process, the boom arm must travel past the stationary driller canopy. This scissor action creates a hazardous pinch point area between the drill arm and the canopy as well as the roof. This pinch point area is open and obvious whenever the drill arm is raised.

Information Bulletin No. 90
Subject: Relief Valve
December 2002
Page 2

This same pinch point exists in the mast feed machine. While the fatality on December 13 did not involve a mast feed machine, the same general principles apply: this pinch point area must be avoided.

There is no operational need or reason for anyone to place his head or any body part in this pinch point area. Each operator is responsible for his own safety. The J.H. Fletcher & Co. roof bolting machines are specifically designed to protect an operator from encountering this pinch point. Failure to operate the machine in a safe manner, such as by placing one's head into this pinch point area and activating a lever, is an unauthorized and unsafe practice.

DURING MACHINE MAINTENANCE, BEFORE ANY MAINTENANCE IS PERFORMED TO THE DRILL HEAD, DRILL ARM/MAST OR THE COMPONENTS THEREOF, THE MAINTENANCE PERSONNEL MUST DEENERGIZE THE MACHINE AND ENSURE THAT THERE IS NO HYDRAULIC PRESSURE IN THE VALVE BANK TO THE DRILLING ARM/MAST AND MECHANISM. SPECIFIC INSTRUCTIONS FOR MAINTENANCE PERSONNEL ARE PUBLISHED IN EACH MACHINE'S MAINTENANCE MANUAL.

J.H. Fletcher & Co. posts safety-warning labels on the drill arm and mast reminding operators to avoid this pinch point.¹ A copy of all warning labels, which J.H. Fletcher & Co. mounts on its arm feed machines, and a drawing of the boom arm guard are enclosed with this Bulletin.

Before 1994, all J.H. Fletcher & Co. machines that were equipped with a fast feed mechanism were designed with a single fast feed lever actuation mechanism.

In 1994, J.H. Fletcher & Co. successfully developed a two handed fast feed design, which it has incorporated into all machines designed after that date and all machines which have been returned to it for modernization since that time.

¹ You should regularly inspect all roof bolting machines. If any warning label is removed, defaced or illegible, you should order replacement labels. Call J.H. Fletcher & Co. or one of its distributor's for the proper warning label kit for your particular model of roof drill.

In addition to warning labels, J.H. Fletcher & Co. has previously published warnings through various media about the pinch point hazard. You may contact the Risk Management Department at 304-525-7811 and speak with David Cooper about the various materials available for use with operators such as videotapes, additional copies of Operator's Manuals, etc.

Information Bulletin No. 90
Subject: Relief Valve
December 2002
Page 3

The machine involved in the December 13 fatality was a single fast feed function machine, which had not been modernized. J.H. Fletcher & Co. repeats its previously published warnings and recommendations and urges that all pre-1994 machines be retrofitted to include a two hand fast feed mechanism or that the fast feed mechanism be disconnected immediately.

The State of West Virginia requires a two hand fast feed system or disconnection of any single fast feed function. J.H. Fletcher & Co. is aware of information that the Commonwealth of Kentucky is considering adoption of this same requirement.

As stated, the machine involved in the December 13 accident did not have a two hand fast feed mechanism. Its single fast feed mechanism had not been disconnected. Additionally, the single function fast feed lever had been materially and substantially altered by the attachment of a pipe to the normal control lever. J.H. Fletcher & Co. is of the opinion that this material and unauthorized alteration of the fast feed lever contributed to the death.

IF YOU OWN OR USE A ROOF BOLTING MACHINE THAT HAS A FLETCHER IDENTIFICATION TAG AND A SINGLE FUNCTION FAST FEED MECHANISM WHICH HAS NOT BEEN DISCONNECTED, PLEASE CONTACT DAVID COOPER AT 304-525-7811 IMMEDIATELY.

It is, therefore, essential that you take the following steps immediately:

1. Inspect all Fletcher roof-bolting machines.

If you are using the fast feed lever and it is a single lever handle, immediately remove the handle so that the fast feed function is disconnected. Notify David Cooper at J.H. Fletcher & Co. so that we may evaluate your situation and make the proper recommendations for you to employ with your machine.

Remember that purchasing any two hand fast feed kit from a non-OEM distributor could result in a material alteration of the machine. J.H. Fletcher & Co. cannot certify or evaluate the quality of another manufacturer, vendor or supplier's product. J.H. Fletcher & Co.'s two-hand fast feed kit meets its original manufacturer specifications.

2. All operators should be reminded again to pay attention to all pinch points encountered when operating a machine. Each operator should be reminded by verbal instruction that the pinch point created in every drilling cycle should be avoided and the failure to avoid that pinch point might result in serious injury or death.

Information Bulletin No. 90
Subject: Relief Valve
December 2002
Page 4

To assist you in this reminder warning to operators and users, J.H. Fletcher & Co. encloses the attached handout. You are requested to provide this handout directly to every operator, maintenance personnel, user and foreman so that all persons responsible for safe operation of a machine and its maintenance are reminded of this issue. J.H. Fletcher & Co. also encloses posters for you to place in a location where all persons will be reminded of this issue.

As you may know, J.H. Fletcher & Co. has instructional videos available. Also, if you need additional copies of the Machine Mounted Operator's Manuals, Operator's Manuals, Service Manuals or Maintenance Manuals, which are provided by Fletcher with any machine, please contact David Cooper for reordering.

3. Examine the drill control handles. UNDER NO CIRCUMSTANCE should any handle be altered, added to, changed, bent, lengthened, shortened, or substituted from its original design. Any alteration of these handles can affect the performance of the valve and jeopardize the safety of the operator. For information on replacement handles, we recommend you contact J.H. Fletcher & Co.
4. Always maintain warning labels, boom arm guards on the boom arm, identification tags on the handles, and handle separator guides, and make sure the handles operate freely and in the direction of travel that the original manufacturer has recommended.

J.H. Fletcher & Co. believes that any alteration of the machine can substantially and materially affect the safety of the machine. J.H. Fletcher & Co. does not condone nor authorize any alteration of a machine, nor any remanufacturing of the machine other than by J.H. Fletcher & Co. or its authorized rebuilders.

These warnings and the substance of this Bulletin have previously been published in various media formats.

If you have any questions, please contact David Cooper at 304-525-7811.



DANGER

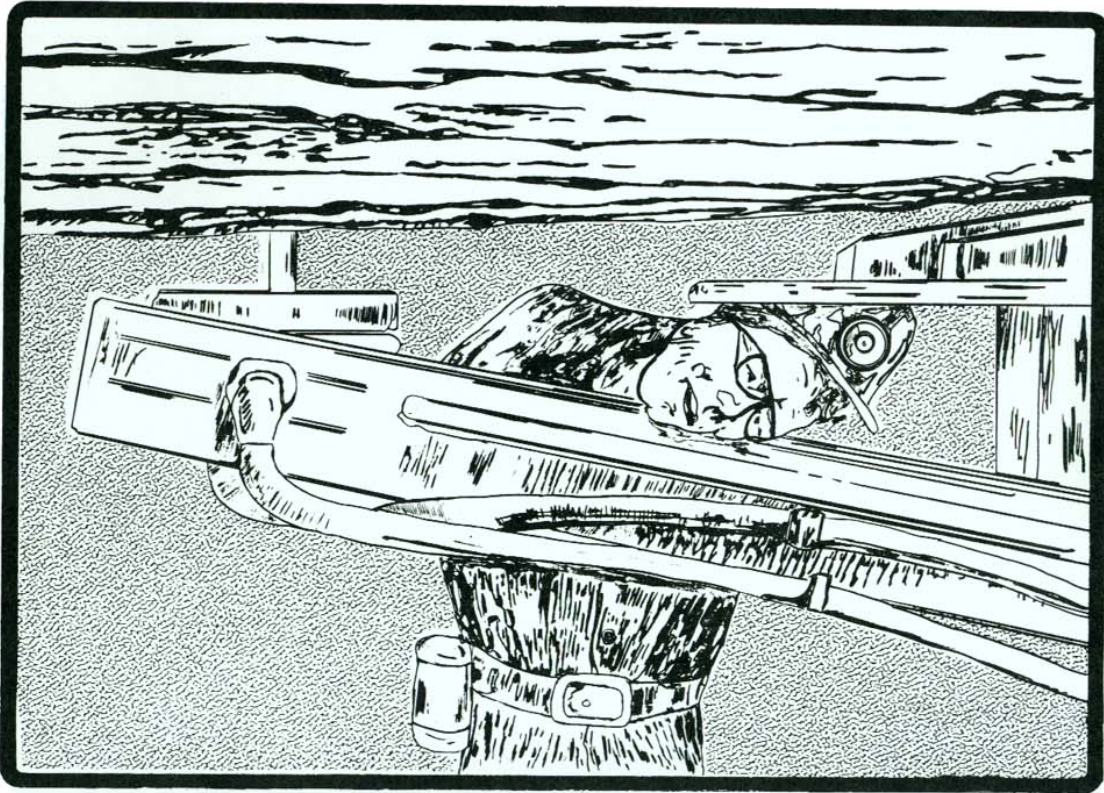

CRUSHING HAZARD!

SERIOUS INJURY OR
DEATH WILL OCCUR!

NEVER PLACE YOUR HEAD OR
ANY BODY PART BETWEEN
BOOM AND CANOPY.

**IMPORTANT SAFETY NOTICE
INFORMATION BULLETIN NO. 50**

TO: ALL OPERATORS OF ARM FEED ROOF BOLTERS

FROM: J. H. FLETCHER & CO.

J. H. Fletcher & Co. wishes to inform you of three fatal accidents to operators of arm feed roof bolters. These accidents resulted from operators placing their head in a hazardous position between the driller canopy and the arm of the feed boom.

Arm feed roof drills incorporate an arm feed boom arrangement. This arrangement allows the boom arm to support the drillhead in the drilling and bolt insertion cycle. In this process, the boom arm must travel past the stationary driller canopy, and this creates a hazardous pinch point area that must be avoided.

If you are operating a bolter, plan to operate a bolter or change out on a bolter during your work cycle, you should be aware that there is the potential for you to get your head or any body part caught between the boom and canopy if you do not stay clear of this mechanism.

TO AVOID THIS PINCH POINT YOU SHOULD:

1. Constantly evaluate your job performance as a roof bolter. Stay clear of all pinch points. Make sure you:
 - A) Have adequate room to bolt.
 - B) Always shut the machine down before performing maintenance on your roof drill.
 - C) Never position yourself as shown in the illustration.
2. Make a visual inspection of your driller controls, checking for the following:
 - A) Make sure your driller control levers are self-centering.
 - B) Never modify or bend your driller control levers.
 - C) Make sure your strip switch is operating properly.
 - D) Maintain all boom arm guards.
3. If you have questions about operating the machine, review your operators manual or consult with your section foreman.
4. Report any unsafe or hazardous operating conditions to your foreman immediately, before continuing.

J. H. Fletcher & Co. feels there is no operational need or reason which requires an operator's head or other body part to be positioned in this hazardous area.

BE ALERT TO THE HAZARDS OF THIS PINCH POINT AT THE DRILLER CONTROLS.

If you have any questions, notify your mine management.

THE DRAWINGS SHOWN ON THE FOLLOWING PAGES ARE TYPICALLY FOUND ON AN RRII/DDO MODEL MACHINE. IF YOU HAVE ANOTHER MODEL OF ROOF DRILL AND WOULD LIKE DRAWINGS SPECIFIC TO YOUR TYPE OF MACHINE, CONTACT THE RISK MANAGEMENT DEPARTMENT OF J. H. FLETCHER & CO., 304/525-7811, ext. 240 or 241, OR EMAIL YOUR REQUEST TO dcooper@jhletcher.com.

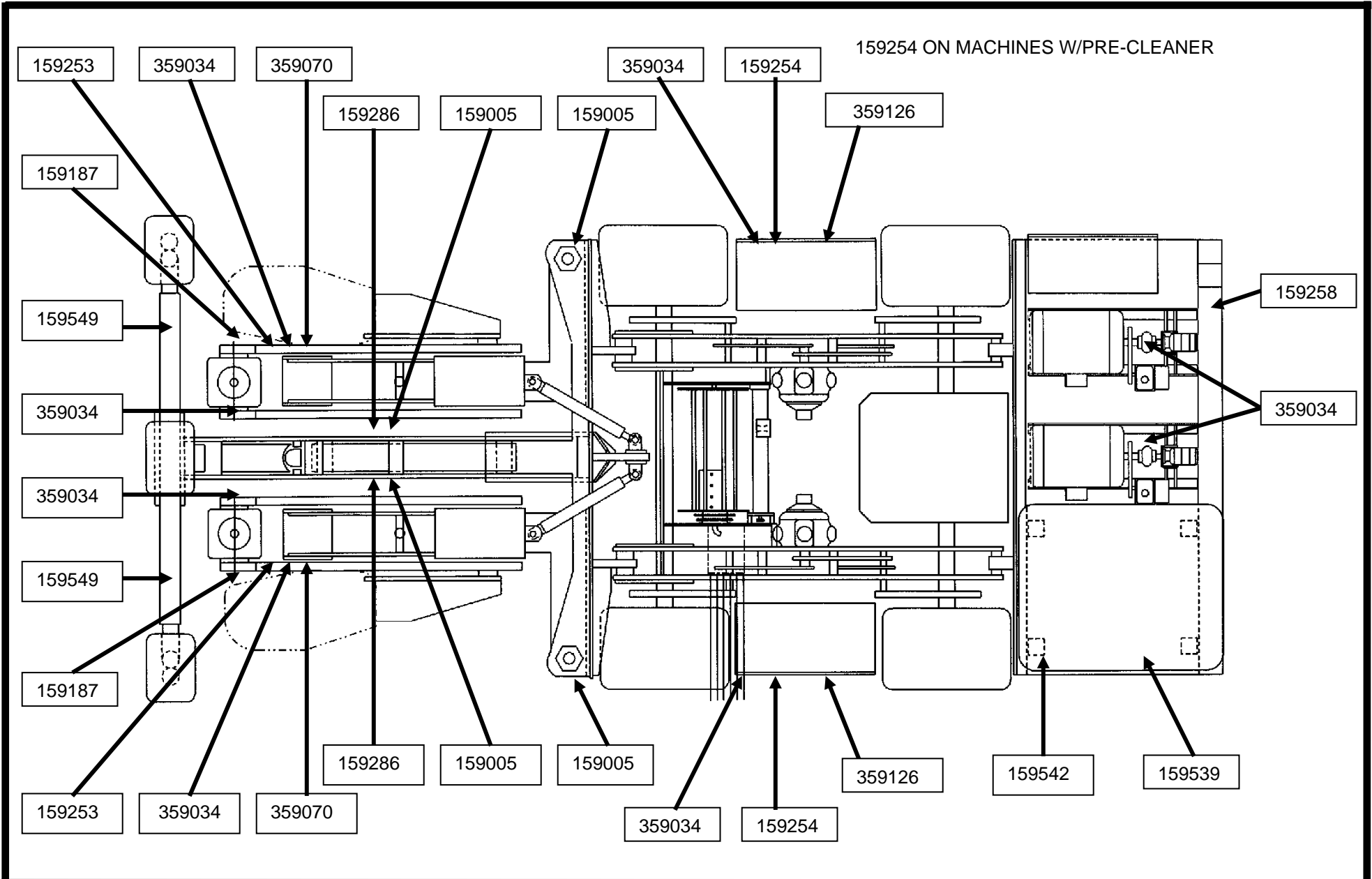

SHEET NO.	TITLE	DATE	R	<p>J. H. FLETCHER & CO. 402 HIGH STREET, HUNTINGTON, WV</p>
P.N. 159172	B/M # 359149 MODEL: RRII (DOG LEG)			

WARNING TAGS

! WARNING

DO NOT ATTEMPT TO OPERATE THIS MACHINE UNLESS YOU HAVE READ THE OPERATOR'S MANUAL AND HAVE COMPLETED THE REQUIRED TASK TRAINING.

BEFORE STARTING MOTOR(S):
 Check the area around the machine for hazards - roof, ribs, floor and methane gas. Eliminate safety hazards before continuing.
 Make sure the machine is in safe operating condition. Make sure all safety devices are present and operating correctly.
 Check control levers for free operation and make sure they are all in the OFF or NEUTRAL position before starting the motor(s).

AFTER STARTING MOTOR(S):
 Test all stop switches and hydraulic disconnects for proper operation.
 Carefully operate all controls to make sure they control the correct machine function and operate in the proper direction at normal speed.

BEFORE LEAVING THE MACHINE:
 Empty all dust collectors and clean or replace filter elements if required.
 Park the machine in a safe location, under permanently supported roof with wheels blocked or machine angled against the rib to prevent rolling.
 Fully lower all moving parts, turn machine circuit breaker OFF and turn off power to the machine at the power center.
 Report any hazardous or unsafe condition to your supervisor immediately.

GENERAL SAFETY REMINDERS:
 Repairs and adjustments on this machine are to be made only by trained and authorized personnel. Incorrect or unauthorized adjustments can result in equipment damage, personal injury or even death. Refer to the Maintenance, Parts and Operator's manuals for complete information.
 Before performing maintenance, repair or inspection always fully lower or securely block moving parts and lock out electrical power.
 Do not make unauthorized machine modifications or utilize repaired or replacement parts which do not meet original manufacturer's specifications.
 This and all other safety notices must be maintained on the machine at all times - **DO NOT REMOVE THIS NOTICE** - replace as required.

 Part No.: 159539

STOP

! DANGER

**-FALLING ROCK HAZARD-
 WILL CAUSE SERIOUS INJURY OR DEATH.
 NEVER STAND OR TRAVEL BEYOND SUPPORTED ROOF.**

DO NOT REMOVE LABEL

©J.H. FLETCHER & CO., 1987 PART NO. 159549

! DANGER

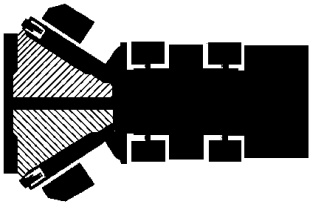

**CRUSHING HAZARD.
 CAN CAUSE SEVERE INJURY OR DEATH.
 NEVER ENTER AREA IN RED UNLESS POWER TO THE MACHINE HAS BEEN LOCKED OUT.**

 INDICATES RED AREA ON TAG

J.H. FLETCHER & CO. PART NO. 159286

! DANGER



**Rotating or whipping drill or bolt.
 Can cause severe injury or death.
 Keep hands off rotating steel.
 Stop drill rotation before completely removing from hole.**

J.H. Fletcher & Co. PART NO. 159253

! WARNING

**PINCH POINT
 COULD RESULT IN DEATH
 OR SEVERE INJURY
 NEVER OPERATE MACHINE
 WITHOUT GUARD IN PLACE**

J.H. FLETCHER & CO. PART NO. 359034

! DANGER



**Crush hazard area.
 Can cause severe injury or death.
 Get clear before moving drill boom.**

J.H. Fletcher & Co. Part No. 159187

DANGER

**! PINCH POINT !
 AREA
 KEEP CLEAR**

DO NOT REMOVE LABEL

 PART NO. 159005

! WARNING



**CRUSH AREA.
 REMOTE ACTIVATED DOOR.
 CAN CAUSE SEVERE INJURY.
 STAY CLEAR.
 DISCONNECT AND LOCK OUT POWER BEFORE SERVICING DUST BOX.**

J.H. FLETCHER & CO. P.N. 159254

! WARNING



**Crushing hazard.
 Can cause severe injury or death.
 Keep all body parts inside compartment when operating.**

J.H. Fletcher & Co. Part No. 159542

WARNING

CRUSHING HAZARD

Boom may fall suddenly.

Can cause severe injury or death.

**Fully lower or securely block all moving parts and
Lock out power before performing maintenance.**

J.H. FLETCHER & CO.
PART NO. 359070

NOTICE

J. H. FLETCHER & CO.: DUST COLLECTION SYSTEM

1. SHUT THE MACHINE OFF.
2. OPEN THE DUST BOX DOOR.

NOTE: IF MACHINE IS EQUIPPED WITH DUST BAG, REVIEW PROCEDURES IN OPERATOR'S MANUAL FOR ADDITIONAL INFORMATION.

3. LOOK AT THE DUST FILTER (DO NOT ATTEMPT TO CLEAN THE FILTER, AS THIS FILTER WILL CONTAIN A HIGH CONCENTRATION OF RESPIRABLE DUST.
4. IF THE DUST FILTER IS EXTREMELY CLOGGED, HAVE MAINTENANCE REPLACE THE FILTER WITH A NEW ONE. IF YOU ARE CHANGING THE FILTER, WEAR APPROPRIATE PPE PROTECTION.
5. PULL OUT THE HEAVIER DUST "FINES" WHICH HAVE GATHERED AT THE BOTTOM OF THE BOX. REMOVE THE FINES BY GRABBING THE TRAY AND PULLING OUT THE DUST "FINES".
6. WHEN YOU ARE REMOVING THE DUST, MAKE SURE YOU STAND ON THE SIDE OR END THAT IS PUSHING FRESH AIR AGAINST YOUR BACK SO THAT THE DUST "FINES" THAT COME OUT ARE BLOWN AWAY FROM YOU.
7. REPLACE THE TRAY IN THE TANK.

NOTE: TRAY NOT SUPPLIED IF DUST BAGS ARE USED.

8. USE A TOWEL/RAG TO REMOVE DUST FROM AROUND THE GASKET ON THE DOOR.
9. CHECK COMPLETE SYSTEM FOR LEAKS OR RESTRICTIONS.
10. SECURE THE DOOR.

SEE SERVICE AND PARTS MANUALS FOR INFORMATION ON THIS SYSTEM.

**USE ONLY J. H. FLETCHER & CO. REPLACEMENT PARTS
TO MAINTAIN MSHA DUST SYSTEM APPROVAL (30CFR PART 33).**



TABLE OF CONTENTS:

[MISCELLANEOUS](#)

[ELECTRICAL](#)

[PUMP SYSTEM](#)

[TRAM SYSTEM](#)

[DRILLING UNIT](#)

[DUST COLLECTION](#)

[SAFETY COMPONENT](#)

[VALVES](#)

[WATER \(OPTIONAL\)](#)

[ORDER FORM](#)



NOT SHOWN: BOOM COVER GUARD BELTS
 299978 50" Lg. (FOR 60" & 72" FEED, 10 to 18" SUMP)
 299979 60" Lg. (FOR 72" & 84" FEED, 18 to 22" SUMP)
 299977 HOLD DOWN BAR
 299976 SPACER BAR (2 REQ'D PER BOOM)

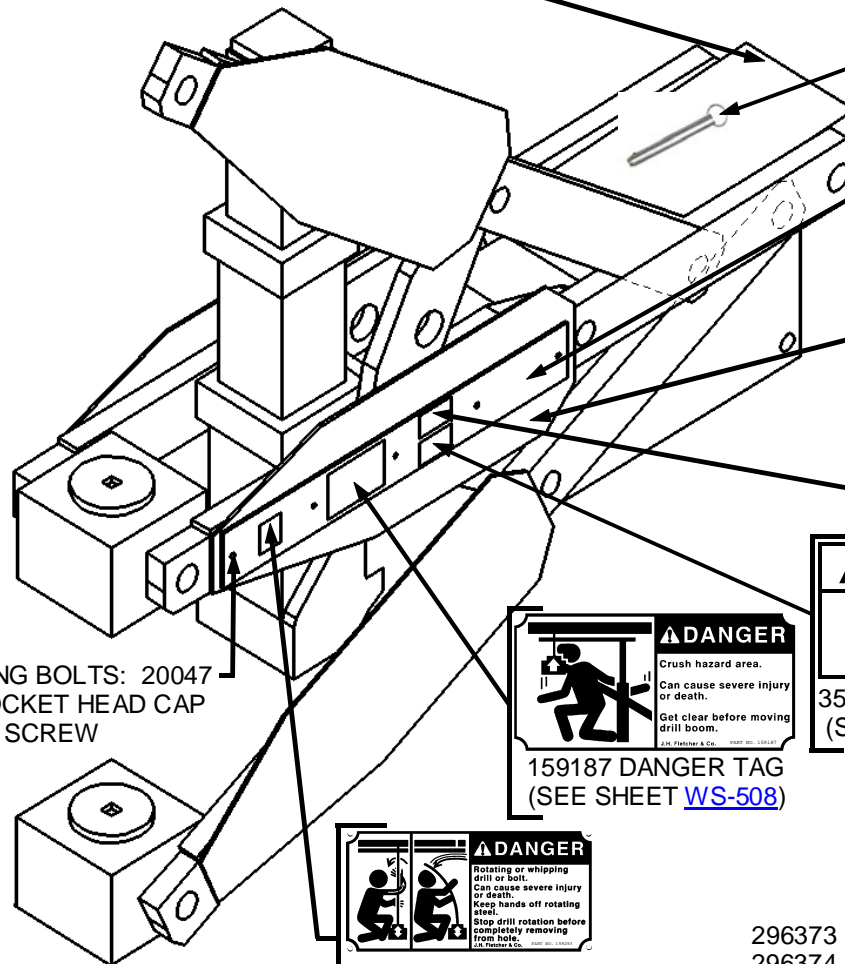
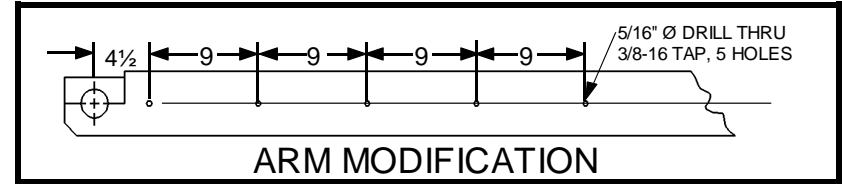

BOOM MAINTENANCE PIN

232697 BELT GUARD RETAINER PLATE 72" & 84" FEED
 235201 BELT GUARD RETAINER PLATE 60" FEED

232696 BELT GUARD (40")
 (5 MOUNTING BOLTS REQ'D FOR EACH) (FOR 72" & 84" FEED BOOMS)
 235202 BELT GUARD (31")
 (4 MOUNTING BOLTS REQ'D FOR EACH) (FOR 60" FEED BOOM)

MOUNTING BOLTS: 20047
 FLAT SOCKET HEAD CAP SCREW

REF: THIS INSTRUCTION SHEET IS PART # 359151

159187 DANGER TAG
 (SEE SHEET [WS-508](#))

⚠ DANGER
 Crush hazard area.
 Can cause severe injury or death.
 Get clear before moving drill boom.
J.H. Fletcher & Co. PART NO. 359187

359034 WARNING TAG
 (SEE SHEET [WS-532](#))

⚠ WARNING
 PINCH POINT
 COULD RESULT IN DEATH OR SEVERE INJURY
 NEVER OPERATE MACHINE WITHOUT GUARD IN PLACE
J.H. Fletcher & Co. PART NO. 359034

359162 DANGER TAG
 (SEE SHEET [WS-600](#))

⚠ DANGER
 CRUSHING HAZARD
 Components could fall or swing.
 Will cause serious injury or death.
 Fully and securely block all moving parts and lock out power before performing maintenance.
J.H. Fletcher & Co. PART NO. 359162

159253 DANGER TAG
 (SEE SHEET [WS-500](#))

⚠ DANGER
 Rotating or whipping drill or bolt.
 Can cause severe injury or death.
 Keep hands off rotating steel.
 Stop drill rotation before completely removing from hole.
J.H. Fletcher & Co. PART NO. 159253

NOTE: USE 25556 1/8" POP RIVET TO SECURE TAGS (4 REQ'D PER TAG)

296373 L.H. GUARD KIT (AS SHOWN) 60" FEED
 296374 R.H. GUARD KIT (OPP. HAND) 60" FEED
 296166 L.H. GUARD KIT (AS SHOWN) 72" & 84" FEED
 296167 R.H. GUARD KIT (OPP. HAND) 72" & 84" FEED

SHEET NO.	TITLE	DATE	J. H. FLETCHER & CO.
MY-1085	BELT GUARD & TAG ARRANGEMENT KIT	4-28-99	402 HIGH STREET HUNTINGTON, WV



TABLE OF CONTENTS:

[MISCELLANEOUS](#)

[ELECTRICAL](#)

[PUMP SYSTEM](#)

[TRAM SYSTEM](#)

[DRILLING UNIT](#)

[DUST COLLECTION](#)

[SAFETY COMPONENT](#)

[VALVES](#)

[WATER \(OPTIONAL\)](#)

[ORDER FORM](#)



FRONT OF MACHINE

RIGHT HAND BOOM VALVE HANDLES

LEFT HAND BOOM VALVE HANDLES

NOT SHOWN:
41617 1/2" HANDLE GRIP
(14 REQ'D, 7 EACH BOOM)

NOTE:
* INDICATES ITEMS NOT PART OF HANDLE ASS'Y.

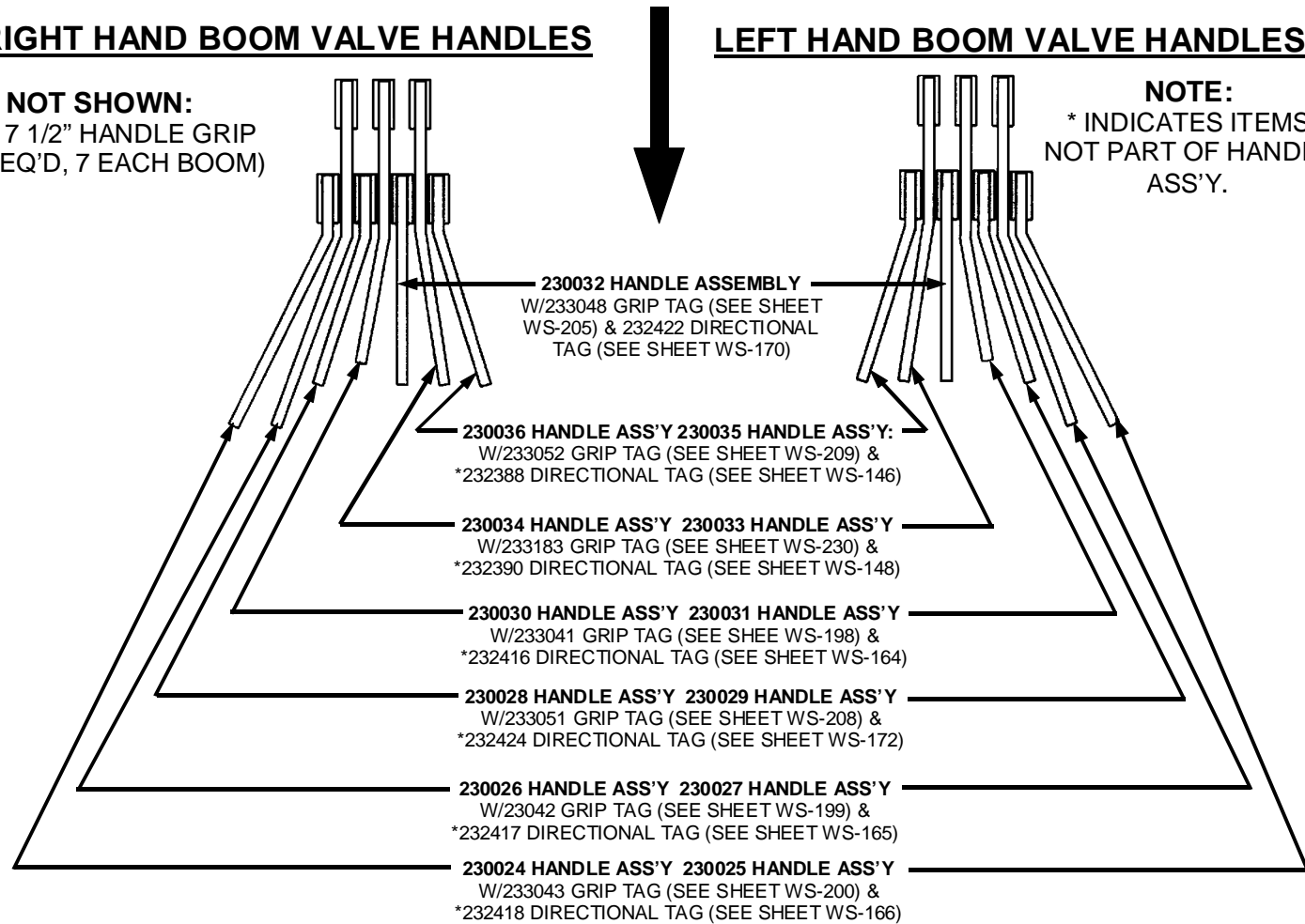

SHEET NO.
HY-253

TITLE
MODEL RR-II & DDO DRILLING UNIT VALVE HANDLE ARRANGEMENT

DATE
11-12-93

J. H. FLETCHER & CO.
402 HIGH STREET HUNTINGTON, WV