

J. H. FLETCHER & CO. Box 2187 – Huntington, WV 25722-2187 – 304/525-7811 – FAX 304/525-4025

IMPORTANT SAFETY NOTICE

INFORMATION BULLETIN NO. 111

TO: CUSTOMERS WITH SPECIFIC FLETCHER DRILL CANOPIES

**FROM: J.H. FLETCHER & CO.
RISK MANAGEMENT DEPARTMENT**

DATE: DECEMBER 2008

SUBJECT: CYLINDER RETAINER PIN ON DRILL CANOPY

All Fletcher roof bolters use, or can use, operator protection canopies. On some models these canopies are attached to an extendable support post actuated by a hydraulic cylinder within the post. The post is mechanically connected to the hydraulic cylinder with a round pin. The round pin is held in place by attaching the canopy, or other attachments, to the support post. If the canopy is not pinned to the post, the hydraulic cylinder pin can dislodge from its connection and fall out. This situation can occur when, or if, the round pin is not properly positioned or maintained or if a canopy is removed for some reason and reattached and the round pin is not placed into the support post and hydraulic cylinder.

Since 2003, Fletcher has made significant changes to the hydraulic cylinder and post arrangement to promote the cylinder and support post staying connected. Fletcher Information Bulletin No. 94, which was previously released, outlined these changes and requested that owners of Fletcher roof bolters notify their maintenance personnel and machine operators that they should inspect the canopy post daily to ensure it is secured to the hydraulic cylinder.

The designs discussed in Information Bulletin 94 (IB 94) have been well received within the industry.

An incident recently occurred involving one of those designs discussed in IB 94 that uses the round pin to connect the canopy cylinder to hold the canopy onto the support post. The round pin was not in place. The canopy was first raised, then lowered. The hydraulic cylinder retracted inside the support post but the support post remained in the raised position. After some time without the support of the hydraulic cylinder the canopy suddenly fell onto the operator, causing injury.

SEE REVERSE SIDE

The support post and cylinder may become disconnected if the canopy or other support post attachment is removed or if the round pin is not properly maintained. One indication of this is that the canopy may not lower immediately from an elevated position when the operator activates the canopy lower control lever, and then, after some time, the canopy may drop unexpectedly.

Anytime the canopy control lever is activated and the canopy does not lower, the operator must not remain under the canopy because it could drop unexpectedly and suddenly. The machine should be evaluated and repaired immediately by maintenance personnel.

In response to this incident, Fletcher recommends that:

1. All operators and maintenance personnel review IB 94 and this bulletin (IB 111). Review your parts books to determine what type of cylinder/support post attachment is on your machine. When you have determined the type of cylinder/support post attachment you have, instruct your maintenance personnel to confirm that the cylinder and support post are securely connected. Fletcher is available to help you determine the style that you have.
2. If you are the owner of a Fletcher machine with the design described in IB 94 that shows the round pin going through the cylinder, Fletcher has an additional update for your bolter (see Machine List in Attachment 1). The pin that goes through the cylinder rod has been modified to reduce any chance that the pin may dislodge and fall out. It is extremely important that the round pin goes through the hole in the cylinder rod. The new round pin has rubber washers on both ends. After the round pin is placed into the hole, the maintenance person must tighten down the bolts on both ends. The tightening of both screws on each end of the pin spreads out the rubber washer in the support post hole. This new design secures the connection and provides a rubber barrier that prevents contamination by dirt or other substances. These round pins can be ordered through Fletcher's Service Department (PN: 413278). Make sure that your parts department and maintenance personnel are aware of the change. Included in this bulletin is a drawing showing the correct part number of the round pin (see Attachment 2). Place a copy of the drawing in the parts book for your machine, and distribute copies to the appropriate personnel. Note: the new pin will be automatically substituted when ordering the previous pin design. Educate your maintenance personnel that anytime the canopy is removed, before reattaching it they must confirm that the cross pin that connects the cylinder rod to the support post is secured in and through the cylinder eye.
3. After the existing pin has been removed and replaced with the new pin, please **DESTROY** the old pin so that it cannot be used again. The warning tag (see Attachment 2) is part of the pin assembly and will be attached to the pin.

The new pin is available at no charge only to the owners of the machines identified by serial number in this bulletin. However, we strongly recommend that all machines be inspected to confirm, as we indicated in IB 94, that whatever system you are utilizing to hold the canopy in place, you ensure that it is secure to the support post cylinder. New machines and Fletcher modernized machines will have the new pin design we have discussed in this bulletin.

To order the new pins (one for each canopy), call the Fletcher Service Department. You will be required to disclose the serial number of the machine, the name of the machine owner, the mailing address and the location of the mine at which the machine is in use. The kit will include one pin assembly and a new parts sheet. Note: Two kits will be required for dual boom machines. Fletcher believes this retrofit should be completed on all machines identified by serial number in this bulletin.

If you no longer own this equipment, we request that you provide us the name and address of the current owner so that a copy of this important Information Bulletin can be sent. J.H. Fletcher & Co. appreciates your cooperation in retraining your employees about this important safety component and with our efforts to complete the retrofit. If you have any questions, please do not hesitate to contact David Cooper (304) 525-7811, or dcooper@jhletcher.com.

MACHINE LIST FOR INFORMATION BULLETIN 111

ATTACHMENT 1

2008600	2007338	2007099	2007026	2006312	2006057
2008406	2007337	2007096	2007022	2006311	2006056
2008405	2007336	2007095	2007021	2006310	2006055
2008315	2007335	2007094	2007020	2006309	2006054
2008312	2007334	2007093	2007017	2006308	2006053
2008310	2007333	2007092	2007016	2006307	2006052
2008307	2007332	2007091	2007015	2006306	2006051
2008306	2007328	2007090	2007014	2006305	2006050
2008304	2007326	2007089	2007013	2006304	2006043
2008303	2007325	2007088	2007011	2006302	2006042
2008301	2007324	2007086	2007009	2006301	2006041
2008300	2007323	2007085	2007008	2006250	2006040
2008220	2007321	2007084	2007007	2006238	2006039
2008217	2007320	2007083	2007006	2006237	2006038
2008215	2007319	2007081	2007004	2006228	2006037
2008213	2007318	2007077	2007003	2006227	2006036
2008209	2007317	2007076	2007002	2006226	2006031
2008208	2007316	2007075	2007001	2006224	2006030
2008206	2007311	2007074	2006501	2006220	2006029
2008203	2007310	2007069	2006500	2006219	2006028
2008073	2007309	2007068	2006463	2006216	2006027
2008027	2007308	2007067	2006462	2006215	2006026
2008024	2007307	2007066	2006433	2006213	2006025
2008018	2007306	2007065	2006429	2006207	2006024
2008008	2007305	2007064	2006428	2006206	2006023
2008005	2007303	2007063	2006427	2006205	2006022
2008004	2007239	2007062	2006426	2006203	2006021
2007814	2007237	2007061	2006425	2006201	2006020
2007813	2007235	2007060	2006424	2006094	2006019
2007503	2007233	2007059	2006423	2006090	2006018
2007499	2007229	2007058	2006422	2006089	2006015
2007459	2007228	2007057	2006414	2006087	2006014
2007457	2007227	2007056	2006413	2006083	2006013
2007446	2007224	2007055	2006407	2006082	2006012
2007445	2007219	2007054	2006331	2006081	2006011
2007443	2007212	2007049	2006330	2006079	2006005
2007442	2007208	2007048	2006329	2006078	2006004
2007440	2007206	2007047	2006326	2006077	2006003
2007439	2007200	2007046	2006325	2006076	2006002
2007421	2007113	2007045	2006324	2006075	2006001
2007418	2007112	2007044	2006323	2006074	2005517
2007416	2007111	2007042	2006321	2006072	2005508
2007347	2007108	2007037	2006320	2006071	2005506
2007346	2007107	2007036	2006319	2006070	2005505
2007342	2007105	2007033	2006318	2006069	2005497
2007341	2007104	2007031	2006315	2006065	2005496
2007340	2007101	2007030	2006314	2006064	2005472
2007339	2007100	2007029	2006313	2006058	2005471

2005469	2005325	2005164	2005111	2005057	2004485
2005468	2005323	2005163	2005110	2005054	2004468
2005462	2005322	2005162	2005109	2005053	2004467
2005461	2005321	2005161	2005108	2005052	2004465
2005459	2005320	2005157	2005107	2005051	2004464
2005458	2005319	2005156	2005106	2005050	2004458
2005456	2005318	2005155	2005105	2005049	2004453
2005455	2005316	2005154	2005104	2005047	2004451
2005425	2005315	2005153	2005103	2005046	2004443
2005424	2005313	2005152	2005102	2005045	2004442
2005423	2005311	2005151	2005101	2005044	2004440
2005420	2005307	2005150	2005100	2005043	2004439
2005418	2005306	2005149	2005099	2005041	2004437
2005412	2005302	2005148	2005098	2005040	2004436
2005404	2005300	2005147	2005093	2005039	2004434
2005403	2005272	2005146	2005091	2005038	2004426
2005385	2005268	2005145	2005090	2005034	2004425
2005380	2005261	2005144	2005089	2005033	2004421
2005379	2005259	2005143	2005088	2005032	2004405
2005377	2005253	2005142	2005087	2005031	2004401
2005376	2005251	2005141	2005086	2005030	2004400
2005375	2005250	2005140	2005085	2005029	2004348
2005374	2005249	2005139	2005084	2005023	2004342
2005372	2005245	2005138	2005083	2005022	2004340
2005367	2005244	2005137	2005082	2005021	2004339
2005365	2005240	2005136	2005081	2005020	2004338
2005362	2005236	2005135	2005080	2005019	2004337
2005359	2005235	2005134	2005079	2005018	2004335
2005358	2005234	2005133	2005078	2005017	2004334
2005356	2005233	2005132	2005077	2005016	2004333
2005354	2005230	2005129	2005076	2005015	2004331
2005352	2005229	2005128	2005075	2005014	2004330
2005351	2005224	2005127	2005074	2005013	2004329
2005350	2005222	2005126	2005073	2005012	2004328
2005348	2005220	2005125	2005072	2005011	2004326
2005343	2005219	2005124	2005071	2005010	2004325
2005342	2005218	2005123	2005070	2005009	2004323
2005341	2005215	2005122	2005069	2005008	2004321
2005340	2005213	2005121	2005068	2005004	2004319
2005339	2005211	2005120	2005067	2005003	2004318
2005338	2005210	2005119	2005066	2005002	2004317
2005335	2005171	2005118	2005065	2004510	2004316
2005334	2005170	2005117	2005064	2004508	2004315
2005332	2005169	2005116	2005063	2004507	2004314
2005331	2005168	2005115	2005062	2004506	2004313
2005330	2005167	2005114	2005060	2004505	2004312
2005328	2005166	2005113	2005059	2004504	2004311
2005327	2005165	2005112	2005058	2004486	2004310

2004309	2004118	2004055	2003338
2004308	2004117	2004054	2003337
2004307	2004116	2004053	2003334
2004305	2004115	2004052	2003329
2004304	2004114	2004051	2003328
2004303	2004113	2004050	2003324
2004301	2004112	2004049	2003323
2004300	2004111	2004048	2003321
2004265	2004110	2004047	2003239
2004264	2004109	2004046	2003211
2004263	2004108	2004045	2003041
2004261	2004107	2004044	2003040
2004259	2004105	2004043	2003039
2004244	2004104	2004042	2003038
2004238	2004103	2004041	2003037
2004235	2004100	2004040	2003036
2004234	2004099	2004039	2003034
2004233	2004098	2004038	2003031
2004225	2004095	2004035	2003030
2004222	2004094	2004032	2003029
2004221	2004093	2004031	2003028
2004220	2004092	2004030	2003027
2004219	2004091	2004026	2003026
2004218	2004090	2004024	2003024
2004215	2004089	2004023	2003021
2004207	2004088	2004022	2002333
2004150	2004087	2004021	2002330
2004149	2004086	2004020	2002328
2004148	2004085	2004018	2001320
2004147	2004084	2004017	
2004146	2004083	2004015	
2004145	2004081	2004014	
2004143	2004080	2004012	
2004142	2004079	2004011	
2004137	2004078	2004007	
2004136	2004075	2004006	
2004135	2007074	2004005	
2004134	2004070	2004004	
2004133	2004069	2004003	
2004132	2004066	2004002	
2004131	2004063	2004001	
2004130	2004062	2003506	
2004128	2004061	2003469	
2004127	2004060	2003461	
2004126	2004059	2003460	
2004125	2004058	2003347	
2004121	2004057	2003342	
2004120	2004056	2003339	

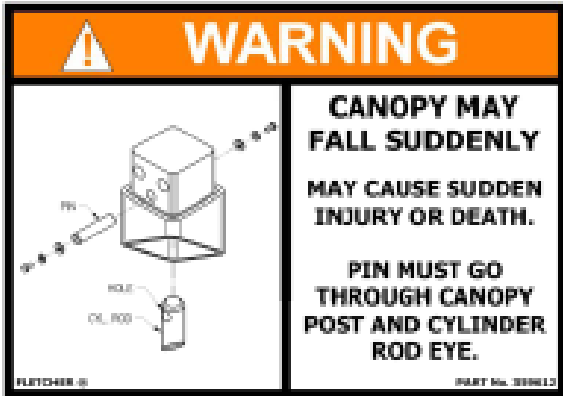

WARNING TAG (SEE SHEET [W8-780](#))

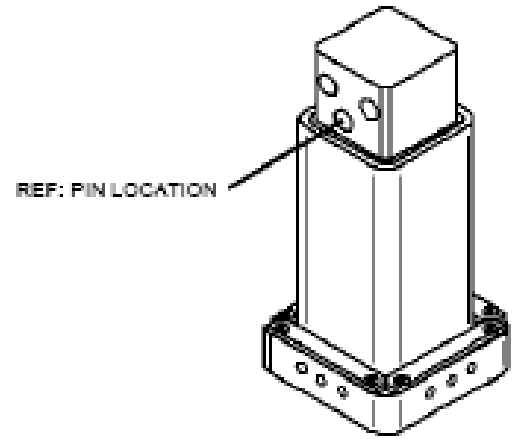

SHEET NO.
MY-2300

TITLE
413278 SUPPORT POST RETAINING PIN ASSEMBLY

DATE
11/02/08

